

Upper Arm

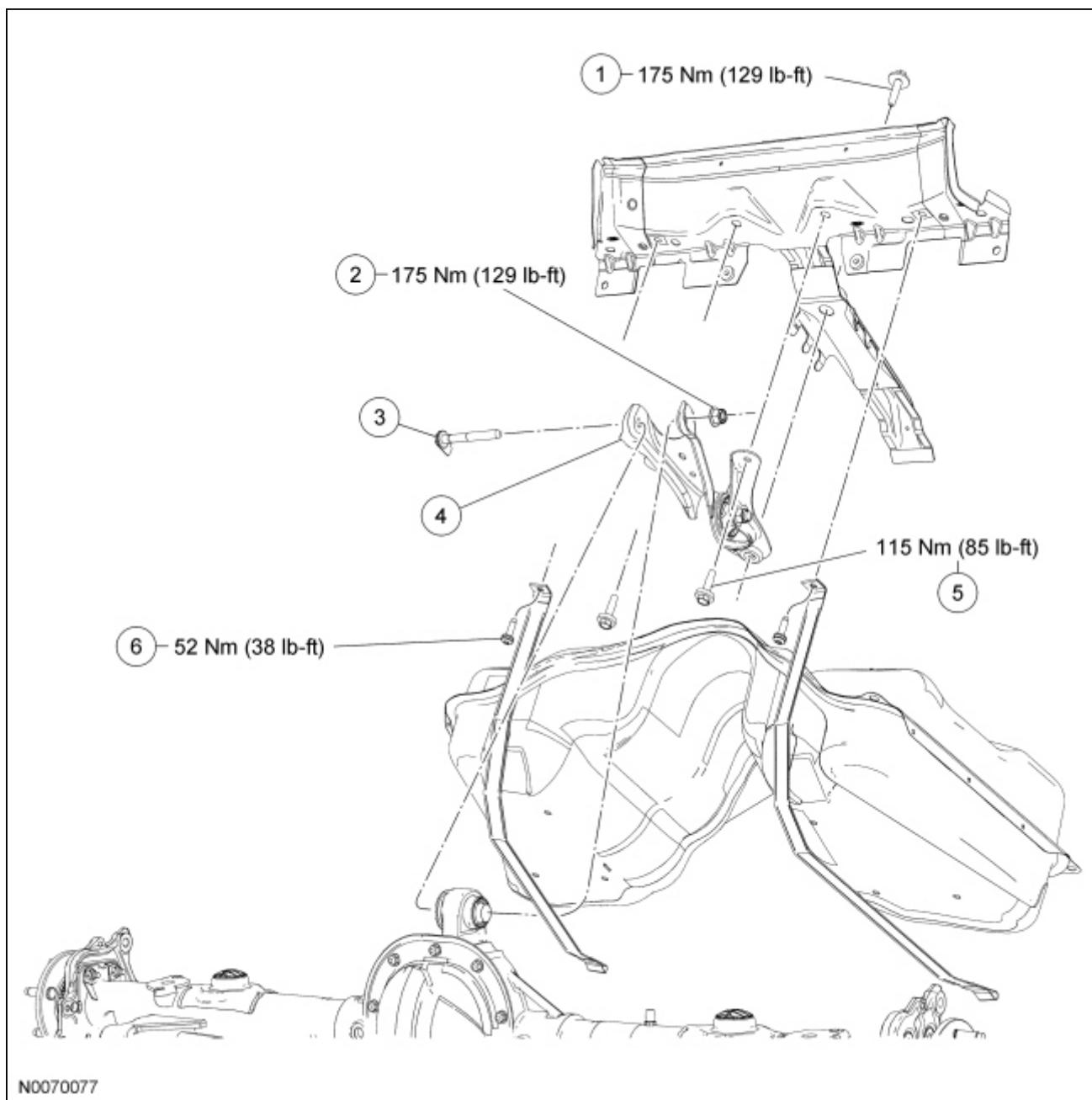

Item	Part Number	Description
1	W708795	Upper arm bracket forward bolt
2	W520215	Upper arm-to-upper arm bushing nut
3	W710443	Upper arm-to-upper arm bushing bolt
4	5K671	Upper arm assembly
5	W711075	Upper arm bracket rearward bolt (2 required)
6	W710947	Fuel tank strap bolt (2 required)

Removal and Installation

NOTICE: Suspension fasteners are critical parts because they affect performance of vital components and systems and their failure may result in major service expense. New parts must be installed with the same part numbers or equivalent part, if replacement is necessary. Do not use a replacement part of lesser quality or substitute design. Torque values must be used as specified during reassembly to make sure of correct retention of these parts.

NOTICE: The upper arm is a 2-piece design and is replaced as an assembly. Do not remove or loosen the nut and bolt that joins the 2 pieces together. The assembly is set at ride height during production, loosening the nut and bolt will disturb this setting.

1. Remove the rear seat cushion. For additional information, refer to [Section 501-10](#).
2. Remove and discard the upper arm bracket forward bolt.
 - To install, tighten the new bolt to 175 Nm (129 lb-ft).

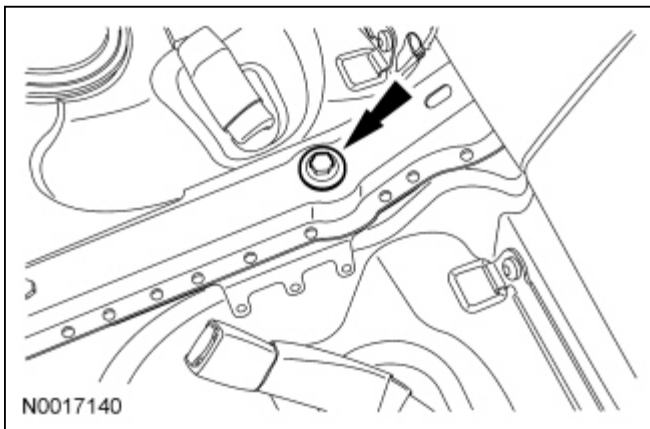

3. To aid in installation, mark the rear shock absorber relative to the protective sleeve with the vehicle in a static, level ground position (curb height).

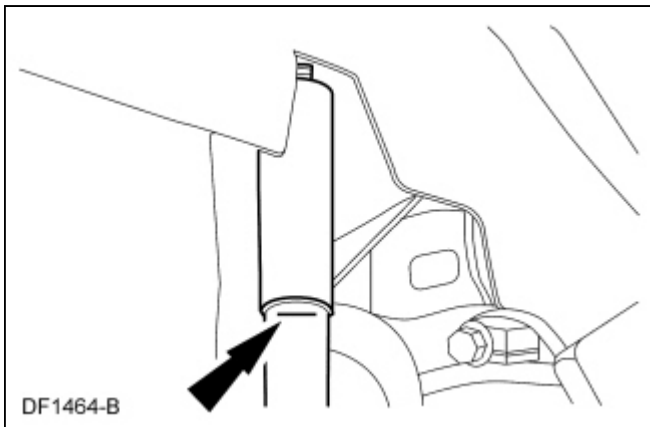

4. With the vehicle in NEUTRAL, position it on a hoist. For additional information, refer to [Section 100-02](#).
5. Place a safety support under the fuel tank.

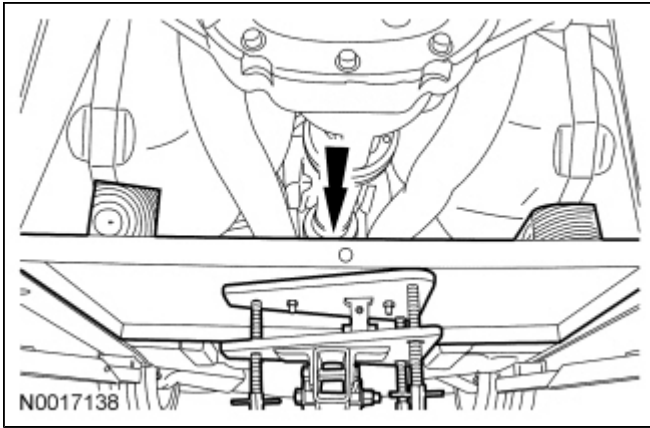

6. Remove the rear bolts from the 2 fuel tank support straps and position both straps aside.
 - To install, tighten to 52 Nm (38 lb-ft).

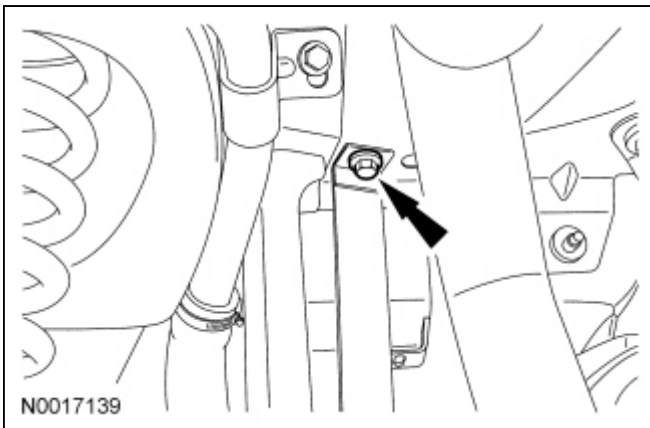

7. Partially lower the fuel tank to gain access to the upper control arm.
8. Remove and discard the 2 upper arm bracket rearward bolts.
 - To install, tighten the new bolts to 115 Nm (85 lb-ft).
9. Remove and discard the upper arm-to-upper arm bushing flag bolt and nut.
 - To install, tighten the new nut to 175 Nm (129 lb-ft).
10. Remove the upper arm assembly.
11. Raise the rear axle so the mark made in Step 3 lines up with the protective sleeve.

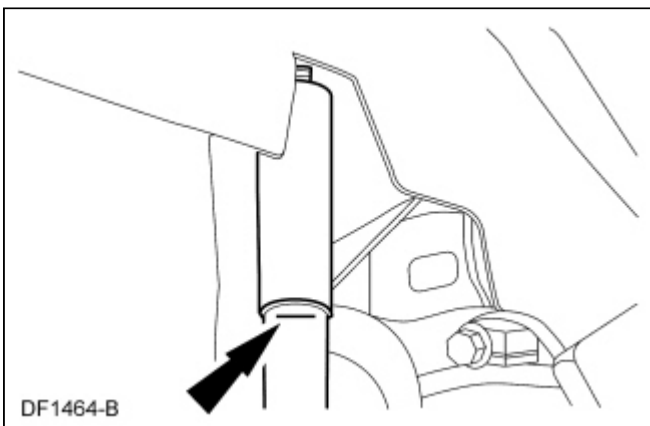

12. **NOTICE:** Tighten the upper arm fasteners while the suspension is at curb height or bushing damage and incorrect clamp load may occur.

To install, reverse the removal procedure.
